

Wzzard™ Intelligent Edge Node

With SmartMesh IP and Bluetooth LE



PRODUCT FEATURES

- Ultra low power 802.15.4e SmartMesh IP technology
- Communicates with Spectre Network Gateway via highly scalable and reliable wireless mesh networks
- 5+ years on battery power
- Wzzard app lets you read or configure the nodes using Android or iOS tablets and smart phones
- Rugged, IP67-rated, fiber reinforced polyester PBT enclosure
- MQTT IoT-ready protocol

SPECIFICATIONS

POWER	
Internal	Two (2) lithium AA batteries
Battery Life	5 + years based on 1 min sensor sampling and reporting
Optional External Input Voltage	3 - 4 VDC
MECHANICAL	
Connector Options	M12 1/2" Conduit, sensor interface cable included; 8 wire, 26 gage, 6 ft.
Optional External Antenna	RP-SMA, Omni-directional, 3.8 dBi, 2.4 GHz Dimensions 7.64 inches (194 mm) Magnetic mounting via internal magnet Pull force 4.7 lbs (2.13 kg) (4) Mounting ears, M5 (#10)
Mounting	IP67-rated, fiber reinforced polyester PBT
Enclosure Weight	0.75 lbs (0.34 kg)
TECHNOLOGY	
Wireless	802.15.4e, SmartMesh IP
Protocols	MQTT-SN
Bluetooth (configurator)	Bluetooth 4.0 Low Energy (LE)
LED	Network Connectivity
ENVIRONMENTAL	
Installation	Indoor or outdoor
Operating Temperature	-40 to 80°C (-40 to 176°F)
Storage Temperature	-40 to 80°C
Operating Humidity	0 to 95% Non-condensing
SECURITY	
Device Authentication	128 bit AES-based encryption with multiple keys
Message integrity check (MIC)	
Synchronized key changeovers	
Customized key rotation	

Wireless Connectivity Where You Need It

The Wzzard™ intelligent wireless sensor platform creates a complete, quick and easy connectivity stack between your sensors and your application, on your network or on the Internet. The platform uses Intelligent Edge Nodes, a wireless 802.15.4e SmartMesh IP network and the IoT-ready MQTT-SN data protocol to transmit sensor data to the Spectre Network Gateway. The Spectre Network Gateway can connect to the Internet via wired connections or the cellular data network.

The Wzzard Intelligent Edge Nodes accommodate virtually any industry-standard external sensors. Connections can be made via 1/2" conduit fitting, cable gland or an M12 connector. The Nodes provide a wide variety of sensor interface options, including general purpose analog inputs, digital input/output and thermocouple. They can also contain internal sensors like an accelerometer, depending upon the model number. All 802.15.4e Wzzard Intelligent Edge Nodes contain an internal temperature sensor.

Secure, Reliable and Highly Scalable Wireless Networking

The Wzzard platform uses mesh networking and time-synchronized channel hopping to provide up to 99.999% connectivity, even in the most demanding RF environments. New nodes may be added at any time, and the SmartMesh IP network will dynamically self-configure as new nodes are added or removed. This is a function of the mesh network itself, and does not need to be controlled by the network gateway.

Easy Configuration and Installation

Configuration of the Wzzard sensor platform is easy via iOS or Android smart phones or tablets. Using the Wzzard app, your handheld devices can configure the Wzzard Intelligent Edge Nodes over their Bluetooth LE connections. The intelligent edge nodes can be configured with calibration and scaling information, eng. units, friendly names, geolocation and other descriptive information.

The platform simplifies physical installation as well. The Wzzard Intelligent Edge Nodes can be attached to any surface using screws or their embedded magnetic bases. The IP67-rated, fiber reinforced polyester PBT housing makes the units deployable in virtually any industrial or commercial environment.

Intelligence at the Network Edge

The Wzzard wireless platform places intelligence at the network edge. The Wzzard Intelligent Edge Nodes can be configured to communicate data only when specified threshold or alert levels are exceeded. When reporting, they can associate useful information like geo-location, device name and uptime. This eliminates unnecessary network traffic, eases the processing burden on upstream resources, and cuts the cost of cellular data plans when the Gateway is using the cellular data network. Thanks to low-power wireless technology and programmable time synchronization, the Intelligent Edge Nodes can operate for up to five years on just two AA lithium batteries.



Wizzard™ Intelligent Edge Node

With SmartMesh IP and Bluetooth LE



SENSOR INTERFACE SPECIFICATIONS

DIGITAL INPUTS	
Voltage range	0 – 48 VDC
V_L	0.97 V Maximum
V_H	1.8 V Minimum
Pull up current	32uA
Type	Sourcing (PNP)/Sinking (NPN) Software selectable input
Isolation	None
FREQUENCY INPUTS	
Channels	2 selectable/shared with Digital inputs
Frequency	0 - 1 kHz
COUNTER INPUT	
Channels	2 selectable/shared with Digital inputs
ANALOG INPUTS	
Input ranges	0 - 5 VDC, 0 – 20 mA
Resolution	12 bit
Input load resistance	100 Mega ohm (0-5VDC), 250 ohm (0 - 20 ma)
THERMOCOUPLE INPUT	
Types Supported	J and K
Ranges Supported	Type J -210 to +1,200 °C Type K -270 to +1,372 °C
Resolution	0.25 °C
Accuracy	Typical +/- 2 °C +/- 6 °C over the temperature range of -40 to 80 °C
DIGITAL OUTPUTS	
Voltage range	0 - 30 VDC
Output Type	Open Drain
Output Current	Not to be less than 100ma
Protection	Current Limit Protection
Isolation	None

INTEGRATED SENSORS

TEMPERATURE	CONDITIONS	MIN	TYP	MAX	UNITS
Offset	Temperature Offset Error @ 25 °C		+/- 0.25		°C
Slope Error			+/- 0.033		°C/ °C
3 AXIS ACCELEROMETER					
Configurable measurement ranges	+/-2 g, resolution of 1 mg/LSB +/-4 g +/-8 g				
Configurable output data rates	12.5Hz, 5Hz, 50Hz, 100Hz, 200Hz, 400Hz				

SMARTMESH IP 802.15.4E RADIO SPECIFICATIONS

PARAMETER	CONDITIONS	MIN	TYP	MAX	UNITS
Frequency Band		2,400		2,4835	GHz
Number of Channels			15		
Channel Separation			5		MHz
Channel Clear Frequency	Where k = 11 to 25, as defined by IEEE 802.4.15		2405 + 5*(k-11)		MHz
Modulation	IEEE 802.15.4 Direct Sequence Spread Spectrum (DSSS)				
Raw data rate			250		kbps
Range	25 °C, 50% RH, +2dBi Omni-Directional Antenna, Antenna 2 m above ground				
	Indoor		100		m
	Outdoor		300		m
Receiver Sensitivity	Packet Data Error Rate (PER) = 1%			-93	dBm
Receiver Sensitivity	PER = 50%			-95	dBm
Output Power	Delivered to a 50 Ω load				
High Calibration Setting				8	dBm
Low Calibration Setting				0	dBm

BLUETOOTH LE RADIO SPECIFICATIONS

NO.	CHARACTERISTICS	CONDITIONS	MIN	TYP	MAX	BT SPEC.	UNIT
1	Operation Frequency Range		2402		2480		MHz
2	Channel Spacing			2			Mhz
3	Output Power	Maximum setting, measured at single ended 50ohm.		4			dBm
		Minimum setting, measured at single ended 50ohm.		-24			dBm
4	Sensitivity, High Gain Mode	High Gain Mode		-93.0		-70	dBm
		Standard Mode		-92.5		-70	dBm

ORDERING INFORMATION

MODEL NUMBER	THERMOCOUPLE INPUT
WSD2CTJ	Wireless Mesh 802.15.4e, 2 Thermocouple J-type inputs, 1 Digital Output; External Antenna, Conduit Connector
WSD1CTJ	Wireless Mesh 802.15.4e, 2 Thermocouple J-type inputs, 1 Digital Output; Internal Antenna, Conduit Connector
WSD2CTK	Wireless Mesh 802.15.4e, 2 Thermocouple K-type inputs, 1 Digital Output; External Antenna, Conduit Connector
WSD1CTK	Wireless Mesh 802.15.4e, 2 Thermocouple K-type inputs, 1 Digital Output; Internal Antenna, Conduit Connector
MODEL NUMBER	ACCELEROMETER and INTEGRATED TEMPERATURE SENSOR
WSD2XV	Wireless Mesh 802.15.4e Integrated Accelerometer; External Antenna
WSD1XV	Wireless Mesh 802.15.4e Integrated Accelerometer; Internal Antenna
MODEL NUMBER	ANALOG INPUT
WSD2MA2	Wireless Mesh 802.15.4e; 2-Analog Inputs, 1 Digital Output; External Antenna, M12 Connector
WSD1MA2	Wireless Mesh 802.15.4e; 2-Analog Inputs, 1 Digital Output; Internal Antenna, M12 Connector
WSD2CA2	Wireless Mesh 802.15.4e; 2-Analog Inputs, 1 Digital Output; External Antenna, Conduit Connector
WSD1CA2	Wireless Mesh 802.15.4e; 2-Analog Inputs, 1 Digital Output; Internal Antenna, Conduit Connector
WSD2MA3	Wireless Mesh 802.15.4e; 3-Analog Inputs; External Antenna, M12 Connector
WSD1MA3	Wireless Mesh 802.15.4e; 3-Analog Inputs; Internal Antenna, M12 Connector
WSD2CA3	Wireless Mesh 802.15.4e; 3-Analog Inputs; External Antenna, Conduit Connector
WSD1CA3	Wireless Mesh 802.15.4e; 3-Analog Inputs; Internal Antenna, Conduit Connector
MODEL NUMBER	DIGITAL INPUT
WSD2MD2	Wireless Mesh 802.15.4e; 2 Digital Inputs, 2 Digital Outputs; External Antenna, M12 Connector
WSD1MD2	Wireless Mesh 802.15.4e; 2 Digital Inputs, 2 Digital Outputs; Internal Antenna, M12 Connector
WSD2CD2	Wireless Mesh 802.15.4e; 2 Digital Inputs, 2 Digital Outputs; External Antenna, Conduit Connector
WSD1CD2	Wireless Mesh 802.15.4e; 2 Digital Inputs, 2 Digital Outputs; Internal Antenna, Conduit Connector

ACCESSORIES

PART NUMBER	DESCRIPTION
9385	External Antenna, 2.4 GHz, 3.8 dBi, Dipole, RP-SMA, hinged
ZXTMT	Cable Gland/Conduit Kit
371-9000-001G	001G Rubber Duck Magnetic Mount Antenna with 5' Cable with RPSMA Plug
ACH2-AT-DP011-G	Magnetic Mount Antenna



APPROVALS AND CERTIFICATIONS

CE	
EN55022	CISPR (EN55022) Class A
EN61000-6-1	Generic Standards for Residential, Commercial, & Light Industrial
EN61000-6-2	Radiated immunity 10 V/m, 80-2700 MHz (EN61000-6-2) or Equivalent
EN61000-4-2	(ESD) +/- 15kV contact, +/- 4kV air
EN61000-4-3	(RFI)
EN61000-4-4	EFT
EN61000-4-5	Surge
EN61000-4-6	CI
EN61000-4-6	Power Frequency Magnetic
EN61000-4-11	Voltage Dips & Interruptions
EN60255-21-1	Vibration
EN60255-21-2	Shock
IEC	
Shock and Vibration	IEC 68-2-6 and IEC 68-2-7 Shock: 30g, 11 ms half sine wave, 18 shocks; Vibration: 0.5 mm p-p, 10 to 60 Hz
FCC	
FCC Part 15 Class A	
FCC - Part 15.247	
Industry Canada - RSS210	
CSA – Class 1, Div 2 Groups A, B, C, D (ANSI/UL equivalent)	
REGULATORY APPROVALS	
ROHS and WEEE Compliant	

MECHANICAL DIAGRAM

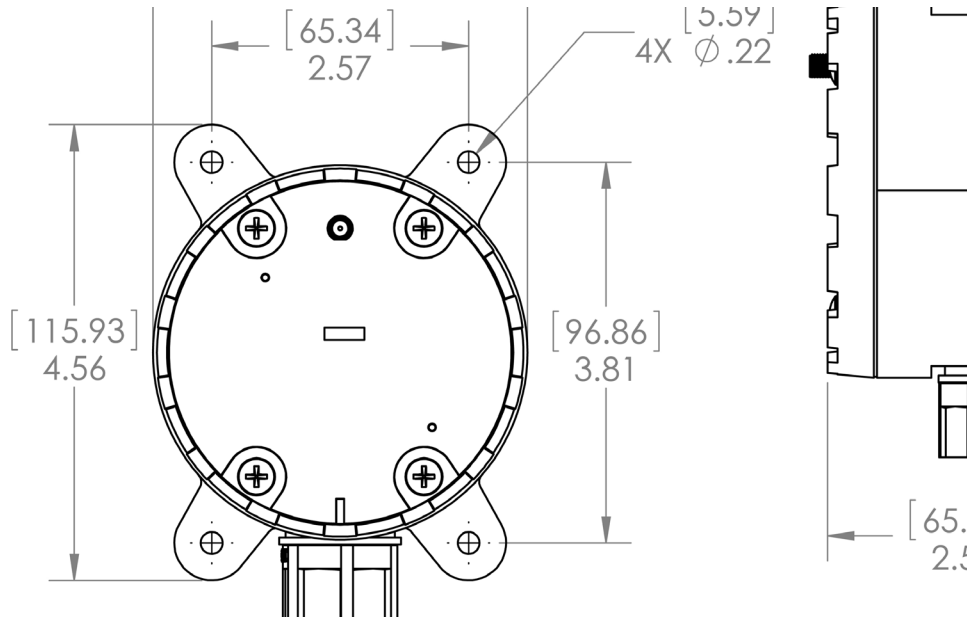

Mouser Electronics

Authorized Distributor

Click to View Pricing, Inventory, Delivery & Lifecycle Information:

B&B Electronics:

[WSD1CA3](#) [WSD2XV0](#) [WSD1CD2](#) [WSD2MA2](#) [WSD1XV0](#) [WSD1MA2](#) [WSD2CTK](#) [WSD2MA3](#) [WSD1CTJ](#)
[WSD1CTK](#) [WSD1CA2](#) [WSD2CD2](#) [WSD1MA3](#) [WSD1MD2](#) [WSD2CA3](#) [WSD2MD2](#) [WSD2CA2](#) [WSD2CTJ](#)