



ITT

Interconnect Solutions
Cannon, VEAM, BIW

Industry leading sealing,
vibration resistance,
and safety in a singular interconnect

CA Triple Thread Connector



Engineered for life

Pioneering Multi-Functional Design

Over the last decades, Cannon delivered more than 5 million CA Bayonet connectors to the marketplace. Originally designed in accordance with the German VG95234 specification, this product is widely regarded as the most versatile and highest reliability connector series among MIL-C-5015 and VG95234 connectors on the market today.

Expanding this product range, ICS proudly introduces the CA Triple Thread interconnect, a new product featuring a triple thread locking mechanism while retaining the broad product layouts of the historical

CA line. This exciting product represents a unique industry offering providing improved vibration resistance in accordance to the stringent ISO 16750 automotive standards.

The triple thread coupling design enables safe and quick connection / disconnection while allowing improved vibration resistance as well as sealing against fluids. These design elements identify particular applicability for truck mounted electrical equipment, off-road and military vehicles, ships, and other ambitious outdoor applications.



CA Triple Thread – Blue Generation Sealing Vibration Resistance Safety

Recognizing the customer driven need for higher sealing and RoHS compliant platings, ITT defined the "Blue Generation" with its revised CA connectors and introduced its new triple thread coupling methodology. These connectors excel in their harsh environment performance by exceeding current CA specifications including the following:

- Sealing degree increase to IP69k
- Salt spray resistance to 96h with a new and attractive RoHS compliant black Zinc Iron plating and improved electrical conductivity
- Optional 500h salt spray resistance with an RoHS compliant Zinc Nickel plating in an attractive blue/grey metallic finish

WHY INNOVATIVE CUSTOMERS CHOOSE ITT

- **Unique triple thread coupling** providing improved vibration resistance and more effective shielding for 100% application reliability in the harshest environments.
- **Rugged shell design, anticorrosive plating, and decades of vibration experience with napkin (linguetta) contacts** defining high reliability in harsh environments.
- **Variety of shell styles and accessories, including 90 degree end bells** allowing for easy adaptation to customer specific applications.
- **Commonality of end bells and tooling with current CA Bayonet products** accommodating lower total cost of ownership.
- **Patented Universal Shielded End Bell with robust sealing capability** enabling safer transmission of signals and improved reliability over competitive products.



Cannon designed insulators are manufactured from high quality polychloroprene to withstand temperatures from -55C to +125C (-67F to +257F) and provide sealing in the unmated condition.

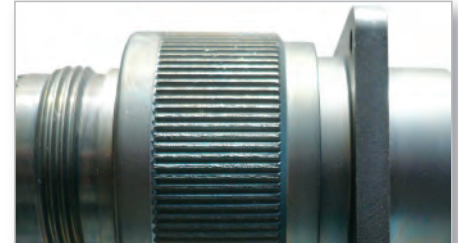

RoHS compliant Zinc Nickel plating in an attractive blue/grey metallic finish ensures integrity against the most severe environmental conditions, including 500h salt spray.

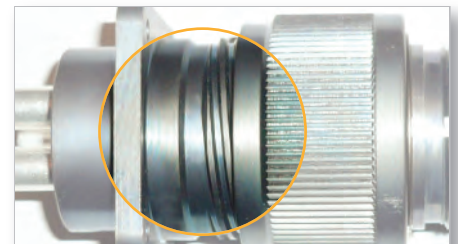

Innovative triple thread design allows safe coupling and uncoupling while providing outstanding vibration resistance to stringent ISO 16750 automotive standards, enabling safe operations in the harshest environments.



Cannon's patented Universal Shielded End Bell provides outstanding strain relief, simplified harnessing, and environmental protection against high-pressure and steam cleaning to IP69k.



The CA Bayonet contacts incorporate copper alloy plated with a hard silver finish (optional gold) and guarantee at least 500 mating cycles. All solder contacts feature a special passivation to comply with RoHS requirements.

Optimized Sealing & Unique Triple Thread Design

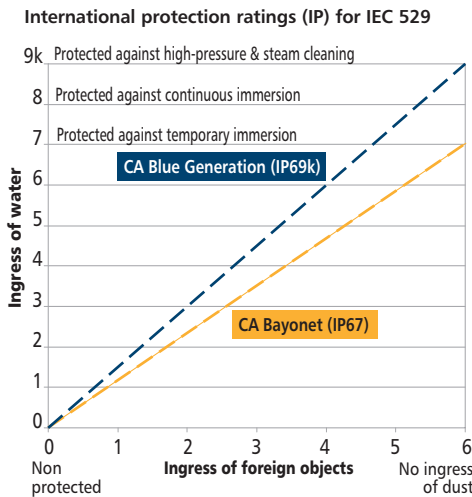

Redefining Environmental Safety – Ensuring Environmental Robustness

Noting the increasing adoption of RoHS standards across multiple industries, ITT Interconnect Solutions adopted an aggressive and proactive stance to ensure the elimination of such materials as chrome 6, lead, and cadmium.

ITT ICS's CA Triple Thread Blue Generation unites RoHS compliance and improved performance, as compared against our tradi-

tional olive green plated non RoHS military products, while offering an attractive black or blue/grey connector plating. Partnered with ITT ICS's pioneering engineering capability and globally deployed manufacturing excellence, we welcome the opportunity to support you in reaching your ecological goals without abandoning your trusted performance.



► For more specifications please see: www.ittcannon.com

APPLICATIONS

- Heavy Diesel Engines
- Heavy Gas Engines
- Diesel Injection Systems
- Defence Systems
- Agricultural Machinery
- Agricultural Equipment
- Construction Machinery
- Power Generating Units
- Gearbox Applications
- Robotics
- Construction machines
- Off road vehicles

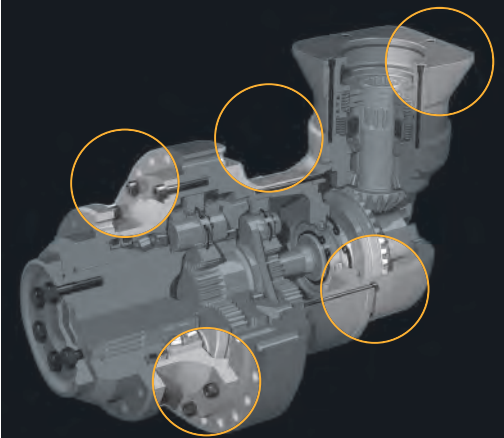

Gearbox sensors, measuring rotary speed and oil temperature, moderating operational efficiency through 100% reliable control signal transmission.



THINK ABOUT ITT

Reliability, Innovation, and Engineered Solutions, these terms collectively describe ITT Interconnect Solutions and define a legacy of Interconnect Science spanning nearly a century, reflecting billions of quality products sold, and incorporating the three industry leading brands of Cannon,

VEAM, and BIW. Our Innovation Timeline uniquely defines a historical compendium of interconnect leadership spanning over 90 years and including many industry firsts; Audio Connectors, Aviation Circulars, D-Sub's, Micro's, fiber optic assemblies, Zero Insertion Force Technologies, and other advanced applications of Interconnect Science. When collaborating with a technology leader, choose a participant with documented trust, established through

multi-industry achievements as substantiated through the participation on every free world space mission, the creation of the first Mil / Spec interconnects, participation on the first talking movie, 100% reliability for over 45 years in Rail applications, and numerous additional achievements in major Military, Aerospace, Industrial, Medical, and Power markets. At ITT ICS, we truly are "Engineered for Life™." Think about ITT.



ITT



Global Design & Manufacturing

Customer Support

North America

MEXICO - Cannon, VEAM

Av. Libre Comercio s/n-
entre Calzada Industrial
Nuevo Nogales y Calzada del Raquet Club,
Parque Industrial Nuevo Nogales
phone: +52.631.3110050
fax: +52.631.3110060

USA - Cannon

666 East Dyer Road
Santa Ana, CA 92705
toll free: 1.800.854.3028
phone: +1.714.557.4700
fax: +1.714.628.2142

USA - BIW

500 Tesconi Circle
Santa Rosa, CA 95401
phone: +1.707.523.2300
fax: +1.707.523.3567

USA - VEAM

100 New Wood Road
Watertown, CT 06795
phone: +1.860.274.9681
fax: +1.860.274.4963

Europe & Middle East

FRANCE - Cannon, VEAM

15, Boulevard Robert Thiboust
Serris, France 77700
phone: +33.1.60.04.93.93
fax: +33.1.60.04.93.90

GERMANY - Cannon, VEAM

Cannonstrasse 1
Weinstadt, 71384
phone: +49.7151.699.0
fax: +49.7151.699.217

ITALY - VEAM

Corso Europa 41/43
Lainate (MI), Italy 20020
phone: +39.02938721
fax: +39.0293872300

LEBANON - BIW

P.O. Box 199
Jounieh
Lebanon
phone: +961.9.911.560
fax: +961.9.912.126

UK - Cannon, VEAM

Jays Close, Viabes Estate
Basingstoke, RG22 4BA
phone: +44.1256.311200
fax: +44.1256.323356

Asia

CHINA - Cannon, VEAM

Tuopandun Industrial Area, Jinda Cheng,
Xiner Village, Shajing Town,
Baoan District, Shenzhen City,
Guangdong, China 518125
phone: +86.755.2726.7238
fax: +86.755.2726.7515

HONG KONG - Cannon, VEAM

Units 2405-6, 24/F, ING Tower
308 Des Voeux Road
Central
Hong Kong
phone: +852.2732.2720
fax: +852.2732.2919

INDIA - Cannon, VEAM

ITT Corporation India Pvt Ltd
2nd Fl Prama House
21 Cama Industrial Estate
Walbhat Road, Goregaon (E),
Mumbai
phone: +91 22 67843000
fax: +91 22 26783033

JAPAN - Cannon, VEAM

11-3, 5 Chome, Hibarigaoka, Zama-shi
Kanagawa, Japan 228-0003
phone: +81.462.57.2010
fax: +81.462.57.1680

SINGAPORE - Cannon, VEAM

10 Jalan Kilang #06-01 Singapore
159410
phone: +65.62763693 ext 232
fax: +65.62763685