

A PERFECT ALLIANCE.

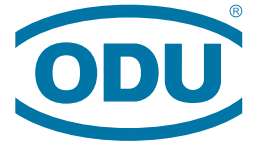

ODU-MAC[®] **White-Line** ZERO

The dynamic hybrid connector.

MANUAL MATING



ODU-MAC[®] WHITE-LINE

ODU-MAC[®] SILVER-LINE

ODU-MAC[®] BLUE-LINE

A PERFECT ALLIANCE.



A PERFECT ALLIANCE.

ODU GROUP OVERVIEW

- More than 75 years of experience in connector technology
- A turnover of 170 million Euro
- Over 1,900 employees worldwide
- 9 sales subsidiaries in China, Denmark, France, Germany, Italy, Japan, Sweden, the UK and the US as well as 5 production and logistics sites
- All technologies under one roof: Design and development, machine tool and special machine construction, injection, stamping, turning, surface technology, assembly and cable assembly

As of February 2018

CERTIFIED QUALITY

- DIN EN ISO 9001
- IATF 16949
- DIN EN ISO 14001
- ISO 13485
- Wide range of UL, CSA, VG and DVA licenses
- UL certified cable assembly

For a complete list of our certifications, please visit our website.

CUSTOMER-SPECIFIC SOLUTIONS

Contacts, connectors and integrated cable assembly solutions meeting the most demanding technical market requirements – ODU's connector solutions and value-added services are characterized by their exclusive focus on meeting the customer's needs.

- Precise implementation of application-specific requirements regarding design, functionality, cost and exclusivity
- Custom connector solutions derived from standard products
- One-to-one local expertise and fair, friendly consulting
- Quick prototyping and production turnaround

All dimensions are in mm. Some figures are for illustrative purposes only. Subject to change without notice. Errors and omissions excepted. We reserve the right to change our products and their technical specifications at any time in the interest of technical improvement. This publication supersedes all prior publications. This publication is also available as a PDF file that can be downloaded from www.odu-connectors.com.

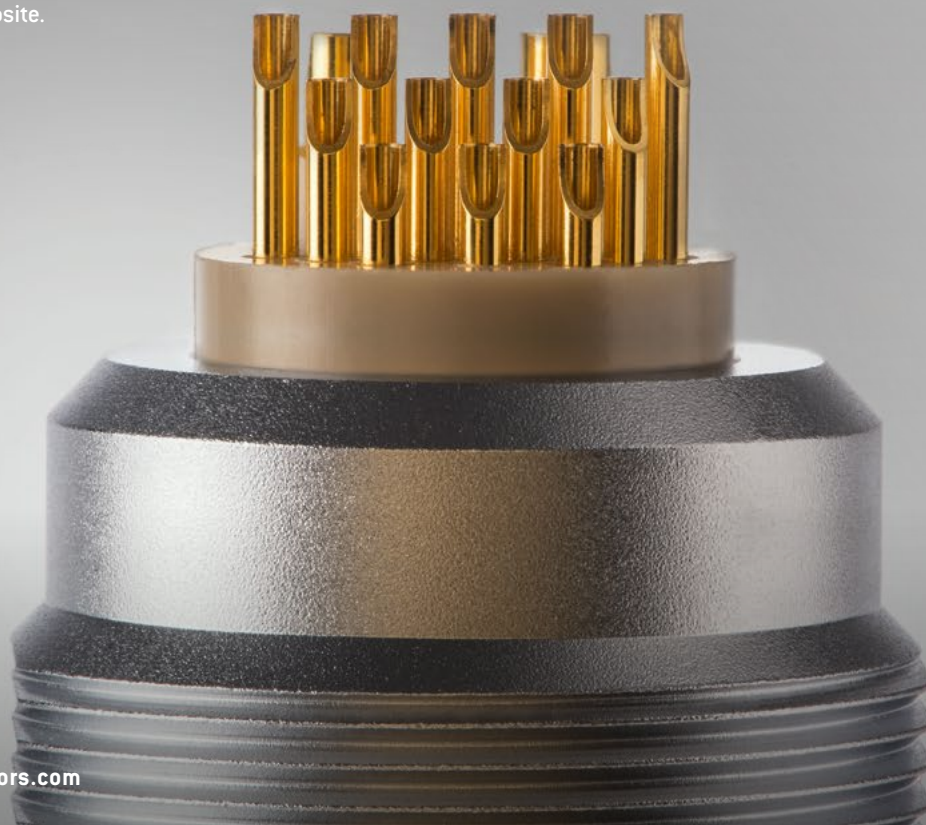

CREATING CONNECTIONS, BUILDING ALLIANCES, COLLABORATING INTO THE FUTURE



Dr.-Ing. Kurt Woelfl

Managing Director

Corporate Development, Engineering, Finance/Controlling, Human Resources, IT & Business Processes, Production, Quality Management, Research & Development, Supply Chain Management

Denis Giba

Managing Director

Corporate Communications/Marketing, Corporate Development, Portfolio Management, Sales

TECHNOLOGY THAT UNITES – CONNECTIONS THAT INSPIRE

For over 75 years, this commitment has enabled us to innovate and provide solutions that respond to continuously changing market needs. We provide high-quality electrical connectors that create added value for our customers and any market player seeking a reliable connector solution to enable the transmission of power, signals, media and data transmission.

A PERFECT ALLIANCE is our guiding principle. It represents the synergy between our high-quality connector solutions and the strong partnerships we build with our staff and business partners across the globe – partnerships based on trust, reliability and mutual respect.

ODU is one of the world's leading suppliers of connector systems today, employing over 1,900 people worldwide and generating approximately €170 million in sales. To ensure the very highest quality standards in our cutting-edge products, we continuously invest in their development and production – and ultimately, in our very unique expertise. Over the past few years, our development of customer- and application-specific connectors has led to the sustained growth of our standard product range so that today, we cover a broad range of application areas. A balance between project-specific business, including customized developments, and standard connector design will continue to shape our business into the future. This holds true

for emerging and future markets, such as medical, military and security, and energy, as well as for the special requirements of measurement and testing, eMobility and industrial electronics.

A PERFECT ALLIANCE – The future of ODU will continue to find solid ground for growth: in our focus on providing reliable connector solutions for a variety of challenging applications and in our commitment to continuously expanding our technology portfolio. It's what we do and who we are – around the globe. This brochure is an invitation for you to become even better acquainted with ODU, an internationally active technology company devoted to creating high-quality customized connector solutions.

We are actively shaping the future of our company with creativity, imagination and innovation in order to serve our valued customers around the world.

ODU – A PERFECT ALLIANCE.

The Managing Directors:

Dr.-Ing. Kurt Woelfl and **Denis Giba**

ODU-MAC® ZERO – THE MINI DYNAMIC PLASTIC HOUSING



SOLID GRIP



BLIND MATING



NON-MAGNETIC



SPACE-SAVING



ONE-STOP CONNECTORS
AND CABLE ASSEMBLY

THE ODU-MAC® ZERO – SMALL SIZE, LARGE VARIETY

When it comes to performance, the ODU-MAC ZERO is nearly on par with its “big brother”. Need a space-saving hybrid connector which can combine several different media? The ZERO from the ODU-MAC product series is your ideal choice. Its symmetric housing geometry enables a generous range – up to 9 units – of signals, power, data-rate and coax modules. In place of an aluminum frame, the plastic housing parts have integrated rails, making the use of magnetic components no longer necessary.

This light, compact multitasker is the result of significant developmental work, with its stylish design making it an innovative eye-catcher.

⊕ IMPRESSIVE – THE ODU-MAC® ZERO

- Suitable for a wide range of ODU-MAC modules
- Can be fitted with 9 units
- Up to 60,000 mating cycles
- 3 different cable outlets: straight, 45°, 90°
- Compact, dynamic housing design
- All touchable parts nickel-free
- Simple, safe housing locking (Break-Away function/emergency release)
- Especially easy to clean
- IP 54

THE MODULAR MULTITASKER

This is how a solid, effective, and attractive overall connection is created – one whose functionality simply can't be surpassed. Confusion due to an excessive number of connections? This challenge belongs to the past – because the customized ODU-MAC ZERO is today's solution.

PRODUCT FEATURES OVERVIEW

- Housing made of 2 plastic half-shells which also form the frame
- Ergonomic housing design with lateral grip recess
- Bio-compatibility upon request
- Easy cleaning thanks to fewer dirt-collecting edges and additional screw cover
- Integrated guiding pins/bushes
- Coding: by guiding pins (\varnothing 4 mm, length 16 mm), housing geometry, coding modules and color-coded cable bend relief varieties
- Low mating/demating forces with approx. 7 N without contacts
- All touchable parts nickel-free
- Black or gray housing upon request



MODULARITY AND ERGONOMIC DESIGN FOR THE SMALLEST OF SPACES







Cable-to-cable hood available upon request.

CONNECTOR HOUSING FOR ASSEMBLY

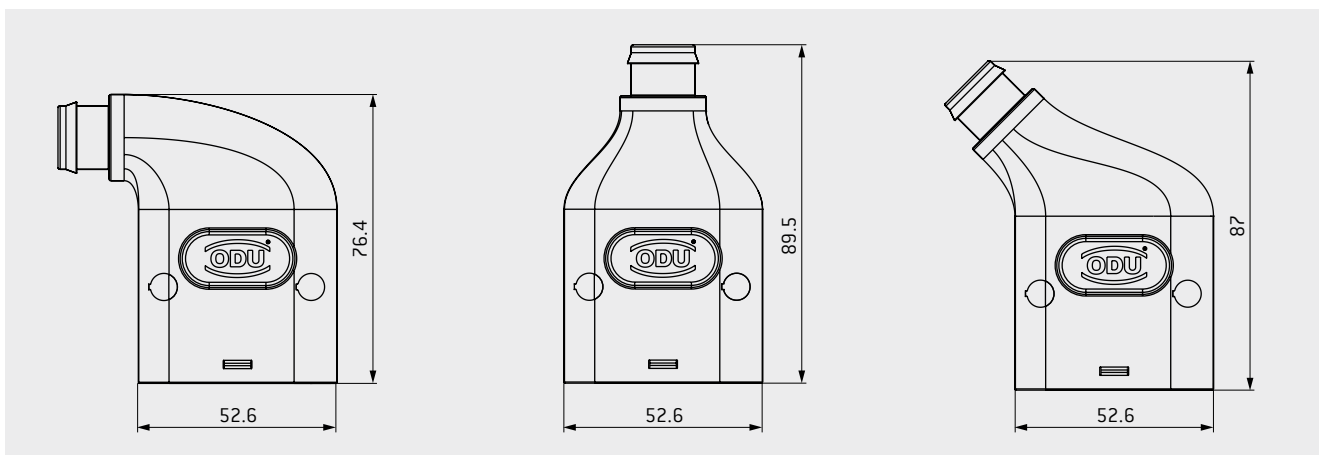
Connector housing for mounting on the cable with different cable entries.
ODU-MAC rail for installing the insulator is already integrated in the housing.

SNAP-IN LOCKING (BREAK-AWAY FUNCTION)



Part number	Cable exit	Size	Units ¹ 2.54 mm
656.560.004.001.000	90°	ZERO	
656.560.006.001.000	0°	ZERO	
656.560.002.001.000	45°	ZERO	

TECHNICAL DATA

Color of housing	White black/gray on request
Locking cycles	60,000
Material	PC Lexan (PEI on request)
Protection class ²	IP 54
Operating temperature	-40 °C to +125 °C
Cable-Ø	8 to 14.5 mm

The cable bend relief must be ordered separately.

¹The frame is already permanently integrated and consists of nine units. ² IEC 60529:2013 (VDE 0470-1:2014).

RECEPTACLE

For integration into the device.

SNAP-IN LOCKING (BREAK-AWAY FUNCTION)

CODING AND PACKAGING DIMENSIONS

Slender, light design with easy, safe handling:

- Maximum mating security through mechanical coding (D-shape)
- Compact, space-saving design with two mounting options

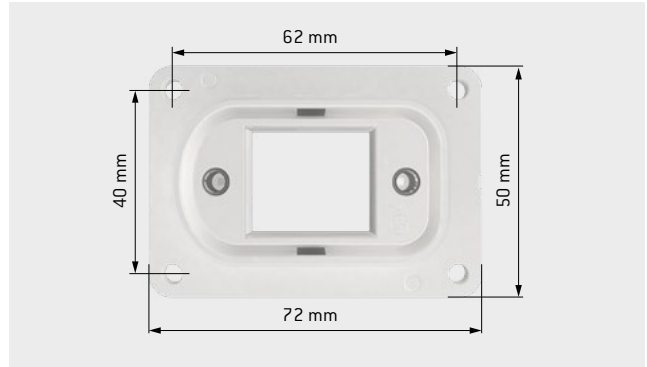

SNAP-IN LOCKING

Easy mating, automatic locking, quick demating option when necessary:

- Quick, reliable housing locking thanks to snap fits and sealing strip (frictional locking principle)
- Low mating/demating forces (approx. 7 N for the housing) guarantee quick connection demating (Break-Away function/emergency release)

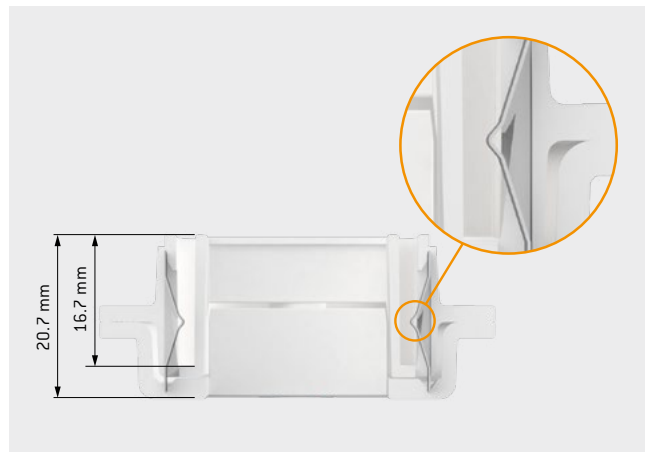

AFFIXING MODULES TO DEVICE PARTS

All module varieties can be quickly, easily and securely integrated:

- Insert module and press the 2 half-shells together
- Affix the device part with screws



MOUNTING FROM BELOW

Mounting with standoffs (not included) is preferable.

MOUNTING FROM ABOVE

Cable-to-cable hood available upon request.

COMPLETE SYSTEMS FROM ONE SOURCE



+ ODU also offers tested and pre-assembled connectors. Our advanced customer benefits include rapid product development, custom connector solution capabilities and manufacturing facilities in Europe, China and the US.

SILICONE BEND RELIEFS

- For cable diameters of 8–14.5 mm (MINI-SNAP size 4)
- Ideal for color coding
- White, gray and black are standard stock – other colors available upon request

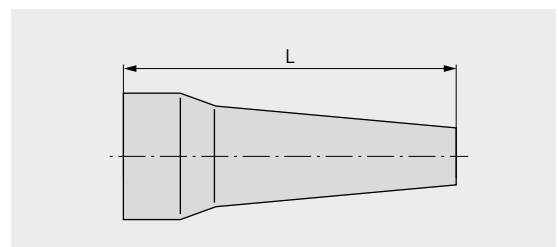

Part number	Dim. L mm	Cable jacket (Ø outside)	
		min.	max.
704.023.____.965.080	60	8	10
704.023.____.965.100		10	12
704.023.____.965.120		12	14
704.023.____.965.140		14	16

Color code	Color	RAL no. ¹ (similar)
202	Red	3020
203	White ²	9010
204	Yellow	1016
205	Green	6029
206	Blue	5002
207	Gray ²	7005
208	Black ²	9005



¹ Due to variations in raw materials, colors may differ slightly from RAL numbers. ² Standard colors with short delivery period.

OVERVIEW OF ALL MODULES

SIGNAL

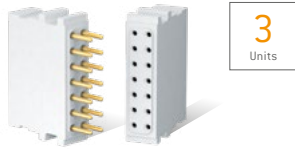

3
Units

+ 14 contacts / Contact Ø: 1.02 mm

- Operating voltage¹ 320 V
- Rated impulse voltage¹ 2,500 V
- Max. continuous current² 13.5 A at 0.5 mm²
- Mating cycles min. 100,000

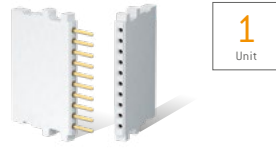

1
Unit

+ 10 contacts / Contact Ø: 0.76 mm

- Operating voltage¹ 250 V
- Rated impulse voltage¹ 1,500 V
- Max. continuous current² 11 A at 0.38 mm²
- Mating cycles min. 100,000

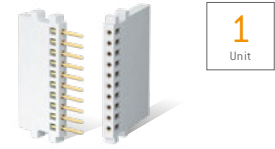

1
Unit

+ 10 contacts / Contact Ø: 0.7 mm

- Operating voltage¹ 32 V
- Rated impulse voltage¹ 1,500 V
- Max. continuous current² 6 A at 0.38 mm²
- Mating cycles min. 5,000



2
Units

+ 6 contacts / Contact Ø: 1.02 mm

- Operating voltage¹ 400 V
- Rated impulse voltage¹ 3,000 V
- Max. continuous current² 13.5 A at 0.5 mm²
- Mating cycles min. 100,000



2
Units

+ 5 contacts / Contact Ø: 1.5 mm

- Operating voltage¹ 500 V
- Rated impulse voltage¹ 2,500 V
- Max. continuous current² 27 A at 1.5 mm²
- Mating cycles min. 100,000

SIGNAL AND POWER



NON-MAGNETIC VERSION FOR SIGNAL AND POWER AVAILABLE UPON REQUEST.

POWER



3
Units

+ 4 contacts / Contact Ø: 2.41 mm

- Operating voltage¹ 500 V
- Rated impulse voltage¹ 3,000 V
- Max. continuous current² 41 A at AWG 12
- Mating cycles min. 100,000



3
Units

+ 3 contacts / Contact Ø: 3 mm

- Operating voltage¹ 500 V
- Rated impulse voltage¹ 3,000 V
- Max. continuous current² 58 A at 6 mm²
- Mating cycles min. 100,000



4
Units

+ 3 contacts / Contact Ø: 3 mm

- Operating voltage¹ 2,500 V
- Rated impulse voltage¹ 10,000 V
- Max. continuous current² 58 A at 6 mm²
- Mating cycles min. 100,000

COAX



3
Units

+ 4 contacts / 50 Ω

- Frequency range 0 to 1.3 GHz
- Mating cycles min. 60,000



5
Units

+ 2 contacts / 50 Ω

- Frequency range 0 to 9.0 GHz
- Mating cycles min. 100,000



5
Units

+ 2 contacts / 50 Ω

- Frequency range 0 to 2.4 GHz
- Mating cycles min. 100,000

¹ Acc. to IEC 60664-1:2007 (VDE 0110-1:2008) for degree of pollution: 2. ² See p. 192 of ODU-MAC Silver-Line | White-Line catalog for definition of max. continuous current.

COAX



+ 2 contacts / 50 Ω

- Frequency range 0 to 2.8 GHz
- Mating cycles min. 100,000



+ 2 contacts / 75 Ω

- Frequency range 0 to 3.0 GHz
- Mating cycles min. 100,000

HIGH-SPEED CONNECTOR/ Shielded implementation/suitable for all common bus systems



USB[®] 2.0³, USB[®] 3.1 Gen1³,
FireWire^{®3}, Ethernet³

+ 2 to 10 contacts / size 0

- Mating cycles min. 10,000

Selected inserts are suitable and certified for data rates of up to 5 Gbit/s (USB[®] 3.1 Gen1³).



USB[®] 2.0³, Ethernet³

+ 2 to 14 contacts / size 1

- Mating cycles min. 10,000
with springwire min. 60,000

Selected inserts are suitable and certified for data rates of up to 1 Gbit/s.



5 Units
3 Units
1 Unit

+ Blank modules



5 Units
3 Units
2 Units
1 Unit

+ Spacer modules



1 Unit

+ Coding modules



1 Unit

+ Pin protection modules

ADDITIONAL MODULES



3 Units

+ Lens connector for POF

- Lens with HFBR ferrule
- Cable type: POF 980/1,000
- Insertion loss < 4 dB with polished fiber

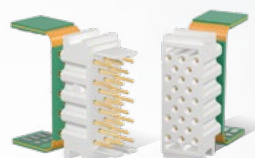

4 Units

+ 8-channel module (coax option)

- Up to 510 MHz
- 100,000 mating cycles
- Easy to assemble

SPECIAL MODULES

³ These ODU specific connectors can transmit common data transmission protocols such as USB[®] 2.0, USB[®] 3.1 Gen1, FireWire[®] and Ethernet, but they are not USB[®] 2.0, USB[®] 3.1 Gen1, FireWire[®] and Ethernet-standard connectors.

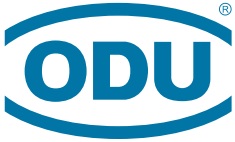

A PERFECT ALLIANCE.

ODU GROUP WORLDWIDE

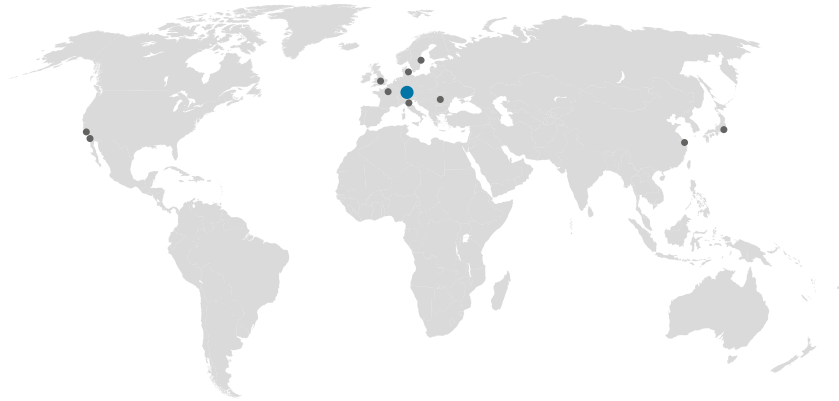

HEADQUARTERS

ODU GmbH & Co. KG

Pregelstraße 11, 84453 Mühldorf a. Inn, Germany
Phone: +49 8631 6156-0, Fax: +49 8631 6156-49, E-mail: zentral@odu.de

SALES SUBSIDIARIES

ODU Denmark ApS

Phone: +45 2233 5335
E-mail: sales@odu-denmark.dk
www.odu-denmark.dk

ODU Japan K.K.

Phone: +81 3 6441 3210
E-mail: sales@odu.co.jp
www.odu.co.jp

ODU-UK Ltd.

Phone: +44 330 002 0640
E-mail: sales@odu-uk.co.uk
www.odu-uk.co.uk

ODU France SARL

Phone: +33 1 3935-4690
E-mail: odu@odu.fr
www.odu.fr

ODU Scandinavia AB

Phone: +46 176 18262
E-mail: sales@odu.se
www.odu.se

ODU-USA, Inc.

Phone: +1 805 484-0540
E-mail: sales@odu-usa.com
www.odu-usa.com

ODU Italia S.R.L.

Phone: +39 331 8708847
E-mail: sales@odu-italia.it
www.odu-italia.it

ODU (Shanghai)

International Trading Co., Ltd.
Phone: +86 21 58347828-0
E-mail: oduchina@odu.com.cn
www.odu.com.cn

Further information and specialized representatives can be found at:

www.odu-connectors.com/contact

PRODUCTION AND LOGISTICS SITES

Germany Otto Dunkel GmbH
China ODU (Shanghai) Connectors Manufacturing Co.Ltd
Mexico ODU Mexico Manufacturing S.R.L. de C.V.
Romania ODU Romania Manufacturing S.R.L.
USA ODU-USA, Inc.
ODU North American Logistics



Simply scan the QR code
to download the entire brochure.

GRASWALD • HEILIGTAG | Passau

ODU-MAC ZERO

ODU-MACZERO/B/0418/E